

Intelligent Vehicle to Control the Illumination in Highways to Avoid Accidents

Pallapu Anusha¹, T.Satya Narayana², P.Bhagya Lakshmi³

¹, Dept Of ECE, CMR Engineering college, Hyderabad, Telangana.

², Associate Professor, CMR Engineering college, Hyderabad, Telangana.

³, Assistant Professor, CMR Engineering college, Hyderabad, Telangana.

Abstract:

The proposed remote-control system can optimize management and efficiency of street lighting systems. It uses Zigbee -based wireless devices which enable more efficient streetlamp-system management, thanks to an advanced interface and control architecture. It uses a sensor combination to control and guarantee the desired system parameters; the information is transferred point by point using Zigbee transmitters and receivers and is sent to a control terminal used to check the state of the street lamps and to take appropriate measures in case of failure or low illumination this will help to provide good light illumination in highways for drivers and hence accidents are avoided.

Key words: Zigbee Module, Light Sensor, IR Sensors, GPRS, GSM Modem.

I. Introduction:

LIGHTING systems, especially in the public sector, are still designed according to the old standards of reliability and they often do not take advantage of the latest technological developments. In many cases, this is related to the plant administrators who have not completed the return of the expenses derived from the construction of existing facilities yet. However, the recent increasing pressure related to the raw material costs and the greater social sensitivity to environmental issues are leading manufacturers to develop new techniques and technologies which allow significant cost savings and a greater respect for the environment. We can find three possible solutions to these problems in the literature.

The first one, and perhaps the most intuitive, is the use of new technologies for the sources of light. In this area, light-emitting diode (LED) technology is the best solution because it offers many benefits. Researchers have already considered this possibility, designing an advanced street lighting system based on LEDs. The second possible solution, and perhaps the most revolutionary, is the use of a remote-control system based on intelligent lamp posts that send information to a central control system, thus simplifying management and maintenance issues. Researchers have developed a street lamp system using the general-packet radio service (GPRS), power-line carrier, or Global Systems for Mobile Communications (GSM) transmissions.

II. The Hardware System

Micro controller: This section forms the control unit of the whole project. This section basically consists of a Microcontroller with its associated circuitry like Crystal with capacitors, Reset circuitry, Pull up resistors (if needed) and so on. The Microcontroller forms the heart of the project because it controls the devices being interfaced and communicates with the devices according to the program being written.

ARM7TDMI: ARM is the abbreviation of Advanced RISC Machines, it is the name of a class of processors, and is the name of a kind technology too. The RISC instruction set, and related decode mechanism are much simpler than those of Complex Instruction Set Computer (CISC) designs.

Liquid-crystal display (LCD) is a flat panel display, electronic visual display that uses the light modulation properties of liquid crystals. Liquid crystals do not emit light directly. LCDs are available to display arbitrary images or fixed images which can be displayed or hidden, such as preset words, digits, and 7-segment displays as in a digital clock. They use the same basic technology, except that arbitrary images are made up of a large number of small pixels, while other displays have larger elements.

I. Design of Proposed Hardware System

VEHICLE SECTION:

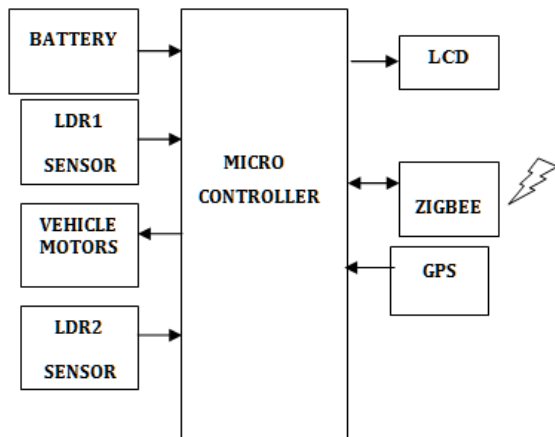

Fig.1. Block diagram

MONITORING SECTION:

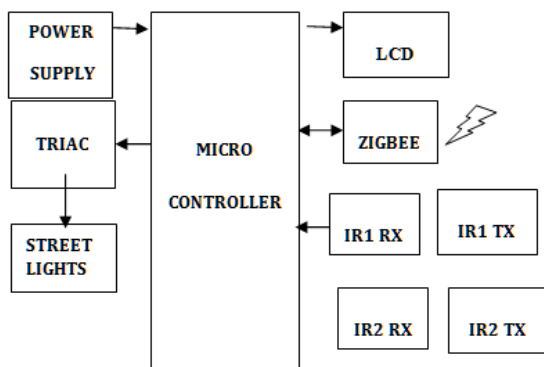

Fig.2. Block diagram

The low illumination on highways may cause to accidents and its not easy to monitor the each and every zone in road so vehicle with light sensors is been sent and will monitor the light intensity and problem with the illumination is controlled automatically by vehicle along with illumination measurement and controlling the speed of vehicles travelling in that specific zone is also noted just for observation purpose and to know the location accurately the vehicle is build with GPS such that it will track the location of the zone from where the readings have been taken,

Board Hardware Resources Features

ZIGBEE:

Zigbee modules feature a UART interface, which allows any microcontroller or microprocessor to immediately use the services of the Zigbee protocol. All a Zigbee hardware designer has to do in

this case is ensure that the host's serial port logic levels are compatible with the XBee's 2.8- to 3.4-V logic levels. The logic level conversion can be performed using either a standard RS-232 IC or logic level translators such as the 74LVTH125 when the host is directly connected to the XBee UART. The below table gives the pin description of transceiver.

- Minimum connections: VCC, GND, DOUT & DIN
- Minimum connections for updating firmware: VCC, GND, DIN, DOUT, RTS and DTR
- Signal Direction is specified with respect to the module
- Module includes a 50kΩ pull-up resistor attached to RESET
- Several of the input pull-ups can be configured using the PR command
- Unused pins should be left disconnected

Data is presented to the X-Bee module through its DIN pin, and it must be in the asynchronous serial format, which consists of a start bit, 8 data bits, and a stop bit. Because the input data goes directly into the input of a UART within the X-Bee module, no bit inversions are necessary within the asynchronous serial data stream. All of the required timing and parity checking is automatically taken care of by the X-Bee's UART. Just in case you are producing data faster than the X-Bee can process and transmit it, both X-Bee modules incorporate a clear-to-send (CTS) function to throttle the data being presented to the X-Bee module's DIN pin. You can eliminate the need for the CTS signal by sending small data packets at slower data rates.

Light Dependent Resistor:

LDRs or Light Dependent Resistors are very useful especially in light/dark sensor circuits. Normally the resistance of an LDR is very high, sometimes as high as 1,000,000 ohms, but when they are illuminated with light, the resistance drops dramatically. Thus in this project, LDR plays an important role in switching on the lights based on the intensity of light i.e., if the intensity of light is more (during daytime) the lights will be in off condition. And if the intensity of light is less (during nights), the lights will be switched on.

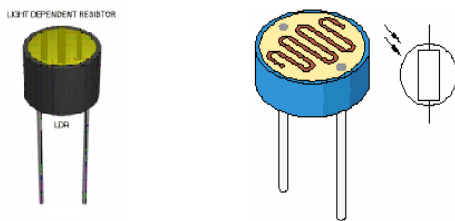

IR SENSOR:

Here the IR transmitter is nothing but the IR LED. It just looks like a normal LED but transmits the IR signals. Since the IR rays are out of the visible range we cannot observe the rays from the transmitter. These are infrared LEDs; the light output is not visible by our eyes. They can be used as replacement LEDs for remote controls, night vision for camcorders, invisible beam sensors, etc.



III. Advantages:

Infrared LEDs are ideal light sources for use with night vision goggles, surveillance cameras, medical imaging, recognition and calibration systems. Due to their resistance to ambient-light impediments and electromagnetic interference (EMI), Infrared LEDs enhance the performance of wireless computer-to-PDA links, collision avoidance systems, automation equipment, biomedical instrumentation, and telecommunications equipment. Solid-state design renders Infrared LEDs impervious to electrical and mechanical shock, vibration, frequent switching and environmental extremes. With an average life span of 100,000-plus hours (11 years), Infrared LEDs operate reliably year-after-year.

GPS:

Global Positioning System tracking is a method of working out exactly where something is. A GPS tracking system, for example, may be placed in a vehicle, on a cell phone, or on special GPS devices, which can either be a fixed or portable unit. GPS works by providing information on exact location. It can also track the movement of a vehicle or person. So, for example, a GPS tracking system can be used by a company to monitor the route and progress of a delivery truck, and by parents to check on the location of their child, or even to monitor high-valued assets in transit.

A GPS tracking system can work in various ways. From a commercial perspective, GPS devices

are generally used to record the position of vehicles as they make their journeys. Some systems will store the data within the GPS tracking system itself (known as passive tracking) and some send the information to a centralized database or system via a modem within the GPS system unit on a regular basis (known as active tracking) or 2-Way GPS.

IV. Conclusion

This paper describes a new intelligent highway lighting illumination system which integrates new technologies available on the market to Offer higher efficiency and considerable savings. This can be achieved using the highly efficient LED technology supplied by renewable energy of solar panels, for which the cost of energy is independent from the power supplier prices, combined to an intelligent management of the lamp posts derived by a control system switching on the light only when necessary, and controlling the illumination to avoid accidents and providing proper vicinity for drivers. Another advantage obtained by the control system is the intelligent management of the lamp posts by sending data to a central station by Zigbee wireless communication. The system maintenance can be easily and efficiently planned from the central station, allowing additional savings. The proposed system is particularly suitable for street lighting in urban and rural areas where the traffic is low at a given range of time. The independent nature of the power-supply network enables implementing the system in remote areas where the classical installations are prohibitively expensive. The system is always flexible, extendable, and fully adaptable to user needs.

The simplicity of ZigBee, the reliability of electronic components, the feature of the sensor network, the processing speed, the reduced costs, and the ease of installation are the features that characterize the proposed system, which presents itself as an interesting engineering and commercial solution as the comparison with other technologies demonstrated. The system can be adopted in the future for loads supplied by the power system, which enables the monitoring of energy consumption. This situation is particularly interesting in the case of economic incentives offered to clients that enable remote control of their loads [31] and can be useful, for example, to prevent the system blackout. Moreover, new perspectives arise in billing and in the intelligent management of remotely controlled loads and for smart grid and smart metering applications.

REFERENCES

- [1] Florida Department of Highway Safety and Motor Vehicles. *Traffic Crash Facts Annual Report 2012*. Appriss, Inc., 2013. Web.

- [2] Hargroves, R.A., "Road lighting," Physical Science, Measurement and Instrumentation, Management and Education - Reviews, IEE Proceedings A, vol.130, no.8, pp.420-441. November 1983.
- [3] Morante, Peter. "Mesopic Street Lighting Demonstration and Evaluation Final Report." *Groton Utilities*. (2008). Web.
- [4] Smadi, Omar, Neal R. Hawkins, and Basak Aldemir-Bektas. *Roadway Lighting and Safety: Monitoring Quality, Durability, and Efficiency*. Ames, Iowa: Institute for Transportation, Iowa State University, 2011.
- [5] Huaguo Zhou, Fatih Pirinccioglu, Peter Hsu. "A New Roadway Lighting Measurement System," *Transportation Research Part C: Emerging Technologies*, Volume 17, Issue 3, June 2009, Pages 274-284.
- [6] Arduino Technical Staff, *Arduino Uno R3*, Arduino, 2011.
- [7] Atmel Corporation, "Atmel 8-bit Microcontroller," ATmega328 datasheet, Feb. 2013
- [8] Fastrax, "Fastrax GPS patch antenna module," UP501 datasheet, May 2013.
- [9] Circuits@Home Technical Staff, *USB Host Shield for Arduino*, Circuits@Home, 2011.
- [10] JAMAR Technologies Technical Staff, *RAC Plus I Distance Measurement Instrument*, JAMAR Technologies, 2012
- [11] Konica Minolta Technical Staff, *Illuminance Meter T-10A/T-10MA*, Konica Minolta, 2012.